

* 所有原料材质, 生产制程, 电镀必须符合HTR要求

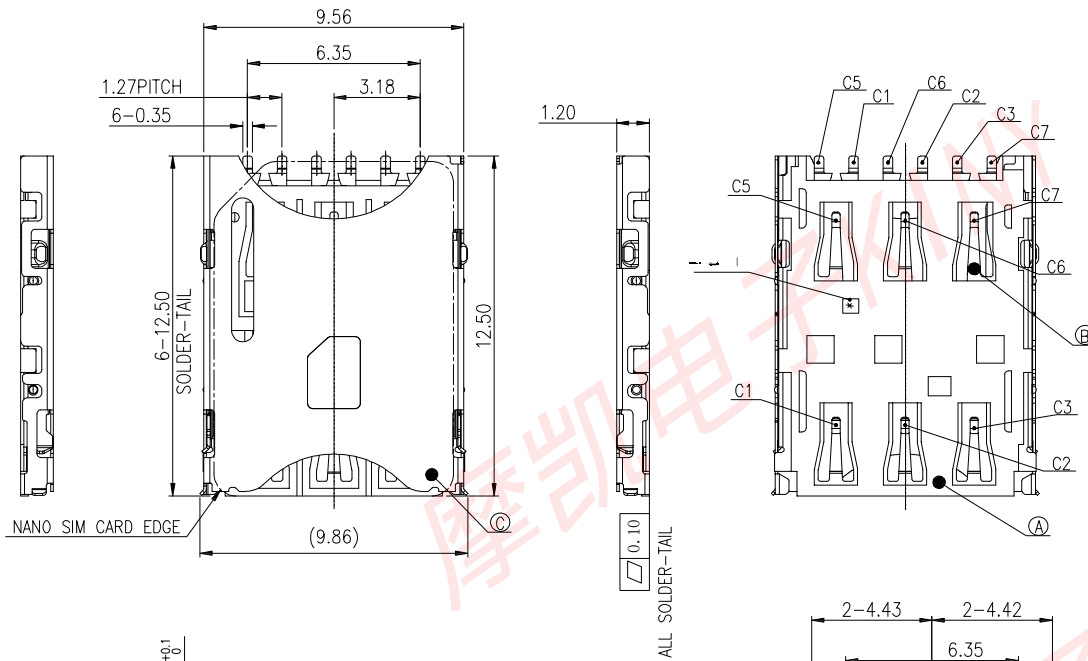

SPECIFICATIONS:

- ELECTRICAL CHARACTERISTICS:
 - CURRENT RATING: 1A .
 - DIELECTRIC WITHSTANDING VOLTAGE: 500V R.M.S MIN;
 - INSULATION RESISTANCE: 500MΩ MIN.
 - CONTACT RESISTANCE: 100mΩ MAX.(INITIAL)
- LIFE TEST: 1500 CYCLES .
- OTHER GENERAL SPEC. TO REFER " NANO SIM SPEC".
- TO CONFORM TO SINGATRON HAZARDOUS SUBSTANCE FREE SPEC.
- HALOGEN FREE PRODUCT IDENTIFICATION MARK ON PRODUCT: ©
- HALOGEN FREE PRODUCT IDENTIFICATION LABEL ON PACKAGING.
- FOR REFLOW SOLDERING LEAD-FREE PROCESS.
- PACKAGING: TAPE & REEL.
- © REPRESENT CRITICAL DIMENSIONS.
- ▽ REPRESENT CPK DIMENSIONS.

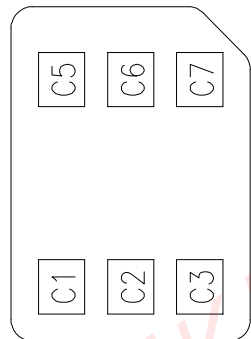
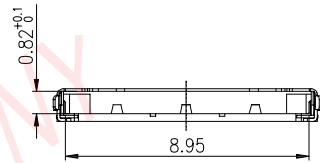

NANO SIM CARD PAD

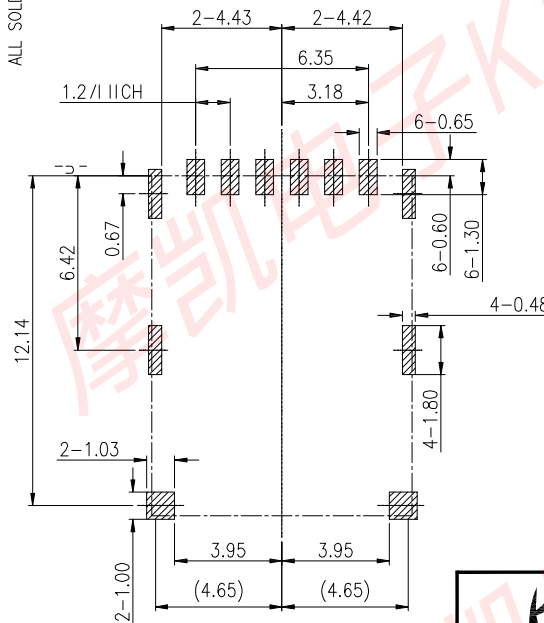

RECOMMENDED P.C.B. LAYOUT
TOLERANCE (TOP VIEW) ±0.05mm

NO	DESCRIPTION	QTY	MATERIAL	PLATING & COLOR
C	SHELL	1	STAINLESS STEEL,0.10T	GOLD FLASH ON SOLDER AREA 50u" MIN NICKEL UNDER-PLATED
B	CONTACT	1	COPPER ALLOY,0.10T	GOLD FLASH ON CONTACT AREA AND SOLDER AREA 50u" MIN NICKEL UNDER-PLATED
A	HOUSING	1	HIGH TEMP. THERMOPLASTIC UL 94V-0	BLACK
NO	DESCRIPTION	QTY	MATERIAL	PLATING & COLOR

KINY

东莞市摩凯电子有限公司

DIMENSIONS INIT: mm
UNLESS OTHERWISE SPECIFIABLE

DIMENSION	TOLERANCE
X.X: ±	0.35
X.XX: ±	0.25
X.XXX: ±	0.10
ANGULAR: ±	2'

PRODUCT NAME : NANO SIM H1.20	DRAWING: Faji	DATE: 2020.04.29
PRODUCT NO. : NS120-T1161-04	CHECK:	DATE:
DRAWING NO. : D-NS120-T1161-04	APPROVED:	DATE:
SCALE: 1:1	DWG ID: C D	REV.: A
		PAGE: 1 of 1

REVISION NO.	ECR NO.	DESCRIPTION	MARK	DATE
1	---	NEW RELEASE	Faji	2020.04.29