

* 所有原料材质, 生产制程, 电镀必须符合H要求

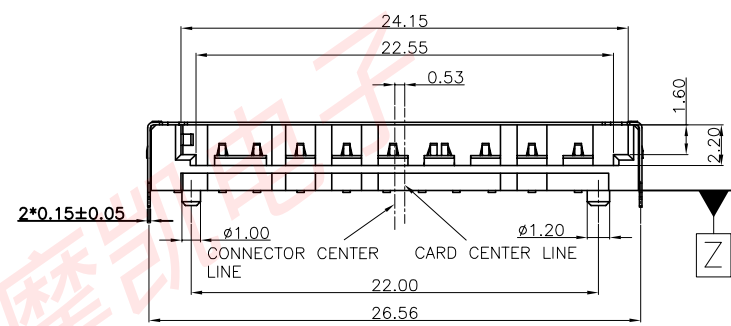
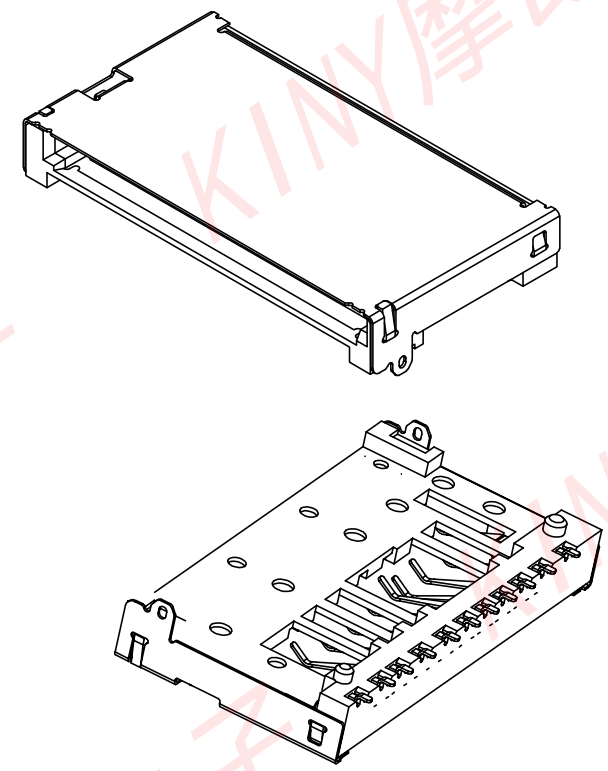
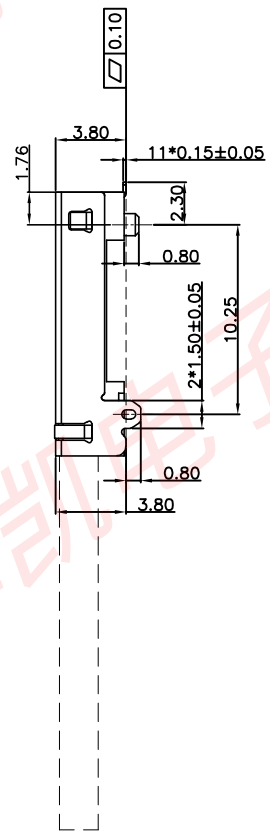
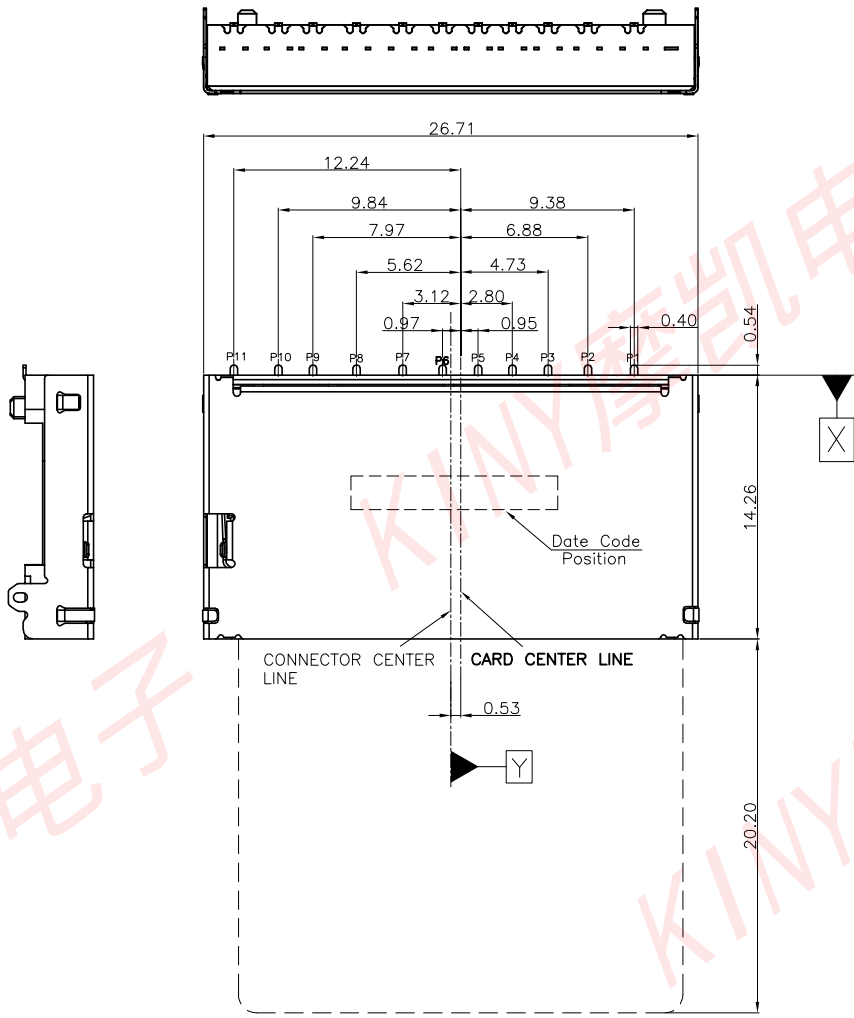

	东莞市摩凯电子有限公司				
	DIMENSIONS INIT: mm UNLESS OTHERWISE SPECIFIABLE	PRODUCT NAME : SD SHORT TYPE STAND OFF 1.0mm	DRAWING: Janyz	DATE: 2019.04.19	
	DIMENSION TOLERANCE X.X: ± 0.38 X.XX: ± 0.25 X.XXX: ± 0.10 ANGULAR: ± 3°	PRODUCT NO. : SDE-T1250-31	CHECK: Alex	DATE: 2019.04.19	
		DRAWING NO. : D-SDE-T1250-31	APPROVED: Alex	DATE: 2019.04.19	
		SCALE: 1:1	DWG ID: C D	REV.: A	PAGE: 1 OF 2

A	---	NEW RELEASE	janyz	2019.04.19
REVISION NO.	ECR NO.	DESCRIPTION	MARK	DATE
1				

* 所有原料材质, 生产制程, 电镀必须符合H要求

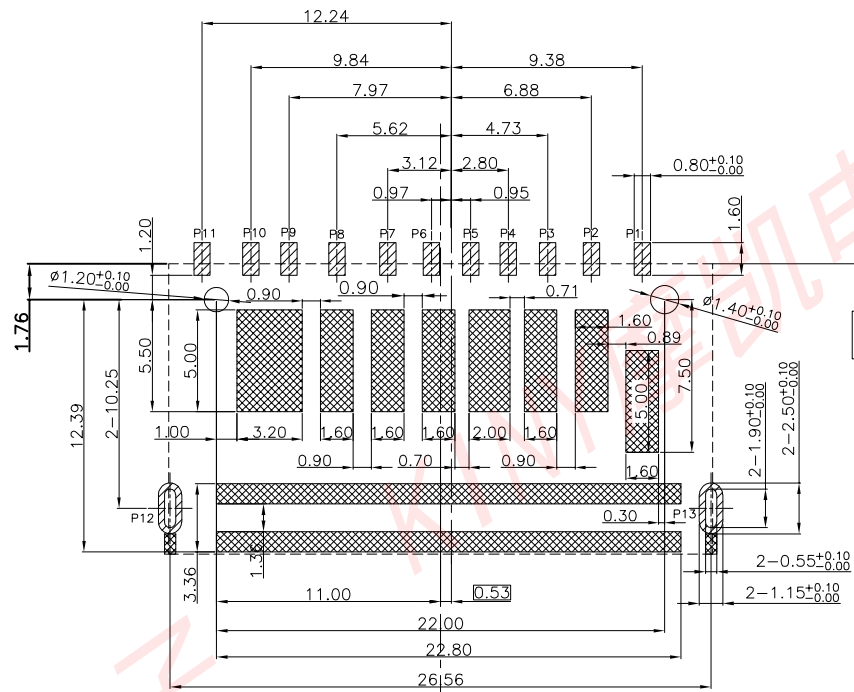

RECOMMEND P.C.B LAYOUT TOLERANCE ±0.05



PAD



No trace , no test point, no via hole, no ground area

WITHOUT CARD		CARD INSERTED:LOCK		CARD INSERTED:UNLOCK	
W/P	GND	W/P	GND	W/P	GND
C/D	VSS1	C/D	VSS1	C/D	VSS1
	P3		P3		P3

Pin Define

Connector Pin No.	SD Card Pin No.	Pin Define
P1	P9	DAT2
P2	P1	DAT3
P3	P2	CMD
P4		CD
P5	P3	VSS1
P6	P4	VDD
P7	P5	CLK
P8	P6	VSS2
P9	P7	DAT0
P10	P8	DAT1
P11		W/P
P12~P13		GND

NOTES :

- Material:
 - Insulator: High Temperature Thermoplastic, (LCP,S475), UL Black 94V-0.
 - Contact: Phosphor Bronze(C5191-EH,T=0.15±0.05mm)
 - Shell: SUS304-3/4H,T=0.15±0.05mm
- Plating:
 - Contact: Plated 50u"min Ni Overall
Plated 1u"min Au Selective Contact Area
Plated 80u"min Sn over Ni on solder area
 - Shell: Plated 50u"min Ni Overall
- Property:
 - Current Rating :0.5A AC/DC
 - Voltage Rating :250VRMS
 - Dielectric Withstanding Voltage: AC 500V r.m.s.
 - Insulation Resistance:1000MΩ minimum.
 - Contact Resistance:100mΩ maximum
 - Operating Temperature:-25°C~90°C
- Part Must Comply Taisol HF WD-3-I-091 Specification.
- Recommending A Metal More Than 0.15mm Thick. Please Confirm Solderability, IF Use A Metal Mask Less Than 0.15mm Thick.
- Packing Specification NO: P-9A212.

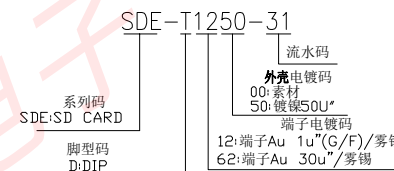

东莞市摩凯电子有限公司

DIMENSIONS INIT: mm UNLESS OTHERWISE SPECIFIABLE DIMENSION TOLERANCE X.X: ± 0.38 X.XX: ± 0.25 X.XXX: ± 0.10 ANGULAR: ± 3'	PRODUCT NAME : SD SHORT TYPE STAND OFF 1.0mm	DRAWING: Janyz	DATE: 2019.04.19
	PRODUCT NO. : SDE-T1250-31	CHECK: Alex	DATE: 2019.04.19
	DRAWING NO. : D-SDE-T1250-31	APPROVED: Alex	DATE: 2019.04.19
	SCALE: 1:1	DWG ID: C D	REV.: A

A	-----	NEW RELEASE	janyz	2019.04.19
REVISION NO.	ECR NO.	DESCRIPTION	MARK	DATE