

* 所有原料材质, 生产制程, 电镀必须符合HTR要求

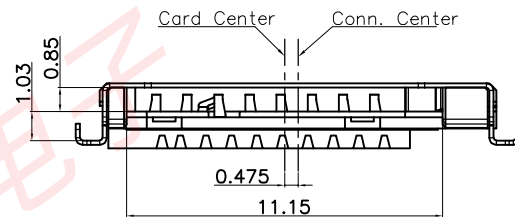
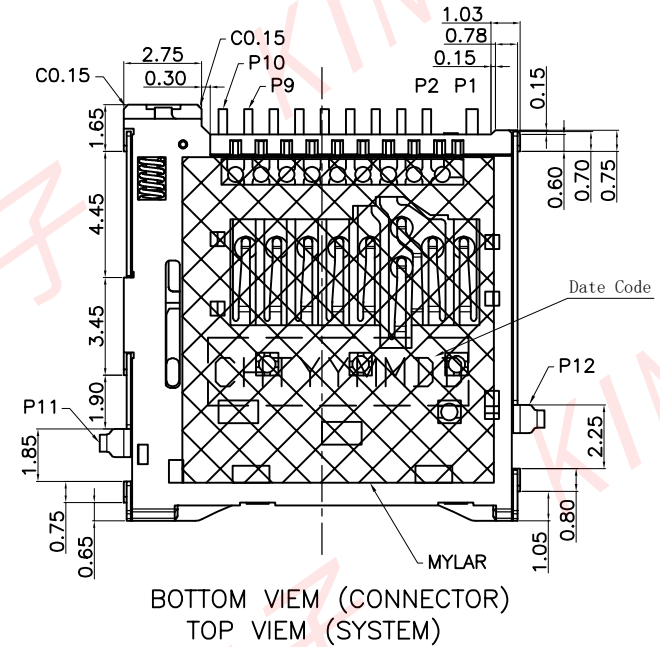
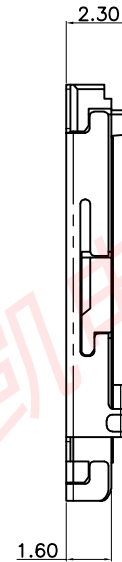
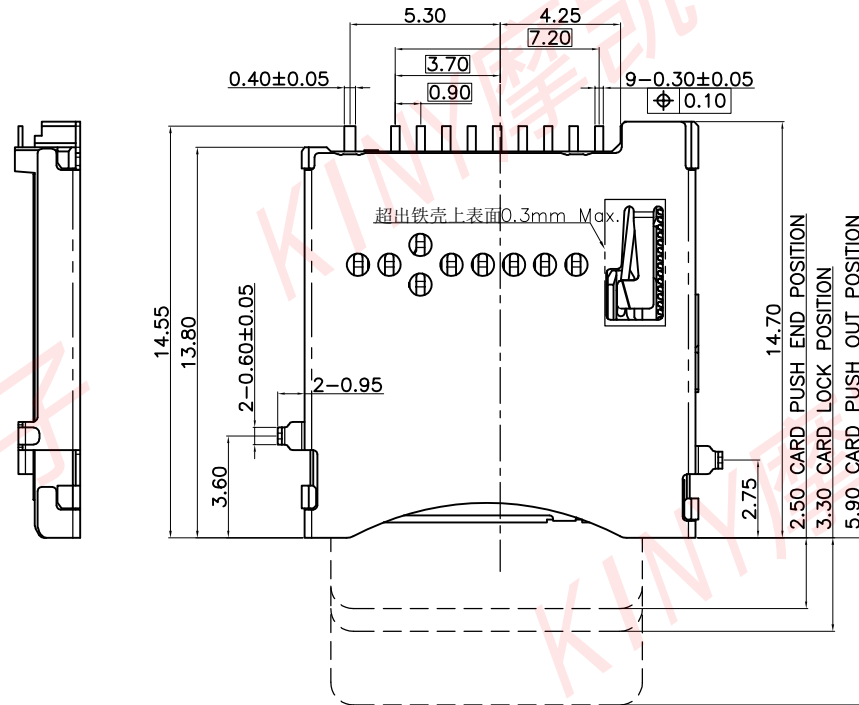
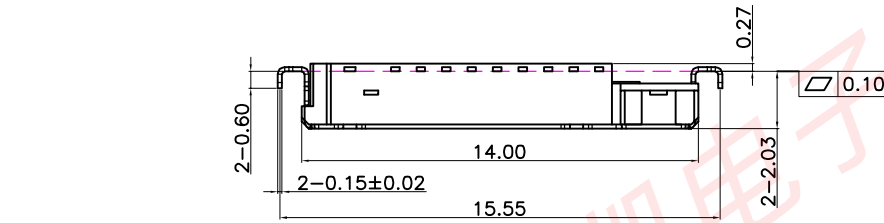

A	---	NEW RELEASE	Faji	2020.04.29
REVISION NO.	ECR NO.	DESCRIPTION	MARK	DATE
1				

	东莞市摩凯电子有限公司				
	DIMENSIONS INIT: mm UNLESS OTHERWISE SPECIFIABLE	PRODUCT NAME : Micro SD P-P Sink H2.30	DRAWING: Faji	DATE: 2020.04.29	
	DIMENSION TOLERANCE X.X: ± 0.35 X.XX: ± 0.25 X.XXX: ± 0.10 ANGULAR: ± 2'	PRODUCT NO. : MS230-T1250-01	CHECK: Alex	DATE: 2020.04.29	
		DRAWING NO. : D-MS230-T1250-01	APPROVED: Alex	DATE: 2020.04.29	
		SCALE: 1:1	DWG ID: C D	REV.: A	PAGE: 1 of 2

* 所有原料材质, 生产制程, 电镀必须符合H要求

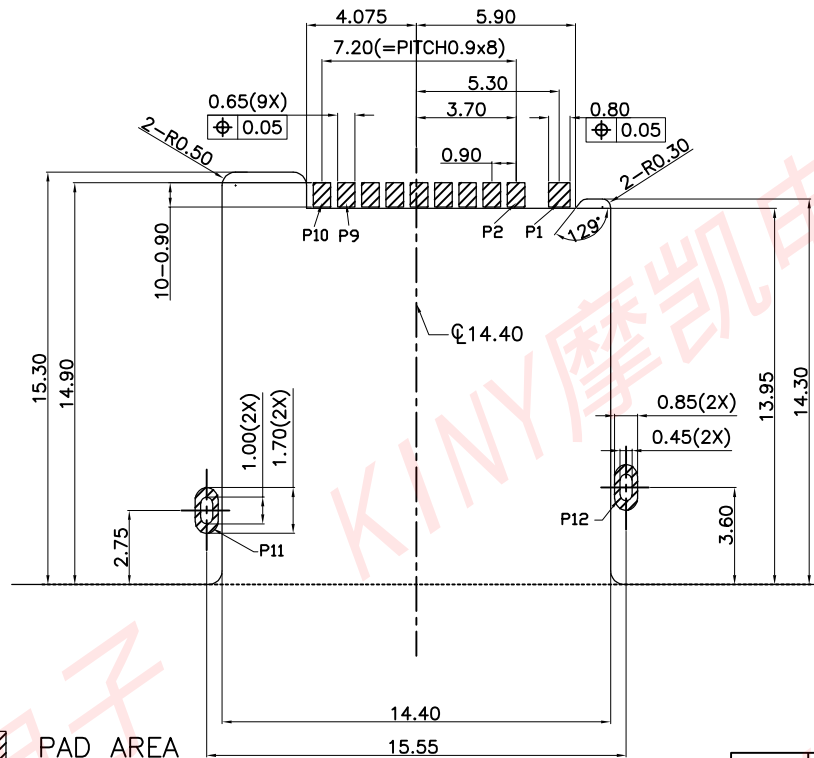

NOTE:

- 1.MATERIAL:
 - 1-1 PLASTICS: HEAT RESISTANCE POLYMER, UL94V-0,COLOR:BLACK
 - 1-2 CONTACT: COPPER ALLOY
 - 1-3 SHELL; STAINLESS STEEL
- 2.PLATING:
 - 2-1 CONTACT:
 - 2-1-1: CONTACT AREA: Au 1u" PLATING OVER Ni.
 - 2-1-2: SOLDER TAIL AREA: MATTE TIN 80u" MIN. OVER Ni. 30u" MIN
 - 2-2 SHELL: SOLDERABILITY Ni PLATING OVER ALL
- 3.CONTACT AND TAIL COPLANARIT TO BE 0.10mm MAX.
- 4.PART MUST COMPLY TAI SOL HF WD-3-1-09I SOPECIFICATION
- 5.RECOMMENDING A METAL MORE THAN 0.10 THICK. PLEASE CONFIRM SOLDILITY, IF USE A METAL MASK LESS THAN 0.10mm THICK.
- 6.PRODUCT PACKING: PLEASE REFER TO THE PACKING REGULATION

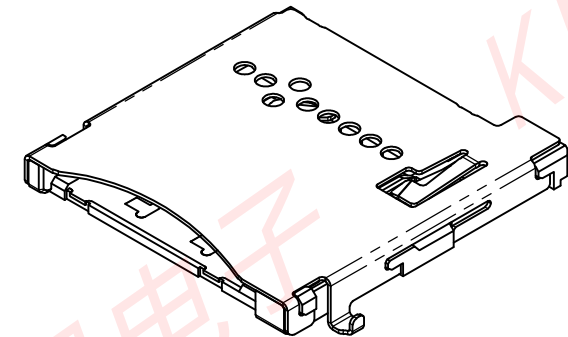

Recommended P.C.B LAYOUT
BOTTOM VIEW(CONNECTOR) (TOLERANCE+/-0.05)
TOP VIEW(SYSTEM)

Opening/Close of Switch

	Card Detect Switch	
Card Uninsertion	Open	
Card Half Insertion	Open	
Card Insertion	Close	
N/O	Open	Close

Pin No.	Pin Assignment
P1	MICRO SD CD
P2	MICRO SD DAT1
P3	MICRO SD DAT0
P4	MICRO SD VSS
P5	MICRO SD CLK
P6	MICRO SD VDD
P7	MICRO SD CMD
P8	MICRO SD CD/DAT3
P9	MICRO SD DAT2
P10	MICRO SD GND
P11	MICRO SD GND
P12	MICRO SD GND

KINNY

东莞市摩凯电子有限公司

DIMENSIONS INIT: mm
UNLESS OTHERWISE SPECIFIABLE
DIMENSION TOLERANCE
X.X: ± 0.35
X.XX: ± 0.25
X.XXX: ± 0.10
ANGULAR: ± 2'

PRODUCT NAME : Micro SD P-P Sink H2.30	DRAWING: Faji	DATE: 2020.04.29
PRODUCT NO. : MS230-T1250-01	CHECK: Alex	DATE: 2020.04.29
DRAWING NO. : D-MS230-T1250-01	APPROVED: Alex	DATE: 2020.04.29
SCALE: 1:1	DWG ID: C D	REV.: A
		PAGE: 2 of 2

A	---	NEW RELEASE	Faji	2020.04.29
REVISION NO.	ECR NO.	DESCRIPTION	MARK	DATE
1				