

* 所有原料材质, 生产制程, 电镀必须符合HTR要求

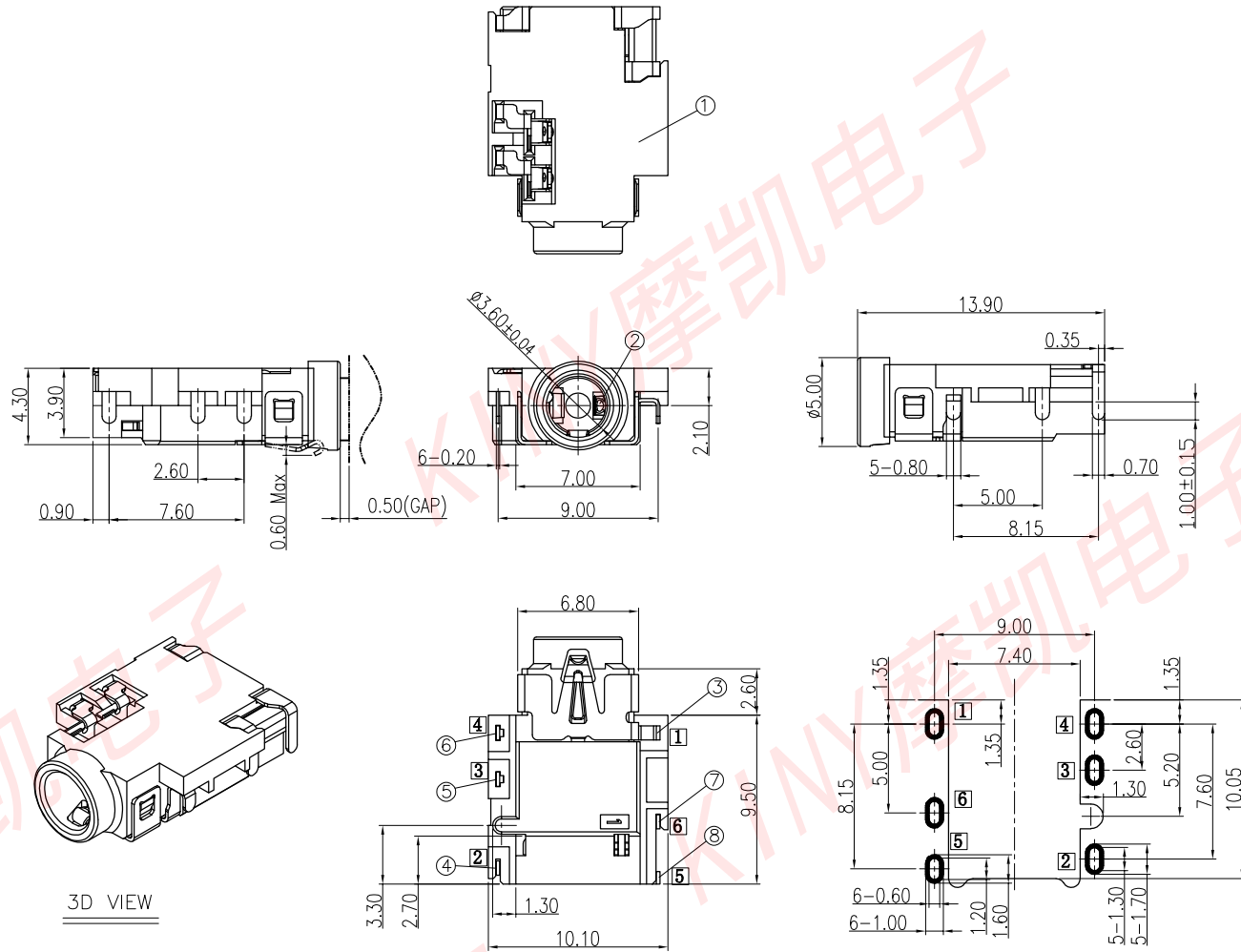

NOTES:

- MATERIAL: SEE "TABLE 1";
- FINISH: SEE "TABLE 1";
- ELECTRICAL:
 - VOLTAGE RATING: 12 VAC RMS;
 - CURRENT RATING: 1.0 AMP;
 - CONTACT RESISTANCE: 50mΩ Max.(Initial), 100mΩ Max.(After Life test);
 - INSULATION RESISTANCE: 100 MΩ Min., 500VDC.(Initial), 50 MΩ Min., 500VDC.(After Humidity test);
 - WITHSTAND VOLTAGE: 500 VAC RMS 50(60)Hz, 1 minute;
- MECHANICAL:
 - MATING FORCE: 0.5-2.2Kgf.(Initial); 0.4-2.2Kgf.(After Life test);
 - UNMATING FORCE: 0.5-2.0Kgf.(Initial); 0.4-2.0Kgf.(After Life test);
 - OPERATING LIFE: 5000 CYCLES MIN.;
- ENVIRONMENTAL:
 - SALT SPRAY: 48H.
 - OPERATION: -30°C~+80°C.

RECOMMENDED P.C.B LAYOUT
TOP VIEW (TOLRANCE:±0.05)

PLUG SPEC		SCHEMATIC		AFTER INSERT SCHEMATIC	
⑤	Contact_5	⑤	1	Phosphor bronze	Au 1u"Min T=0.20mm
⑦	Contact_6	⑥	1	Phosphor bronze	Au 1u"Min T=0.20mm
⑥	Contact_4	④	1	Phosphor bronze	Au 1u"Min T=0.20mm
⑤	Contact_3	③	1	Phosphor bronze	Au 1u"Min T=0.20mm
④	Contact_2	②	1	Phosphor bronze	Au 1u"Min T=0.20mm
③	Contact_1	①	1	Phosphor bronze	Au 1u"Min T=0.20mm
②	Separator		1	HIGH TEMP. PLASTIC	Black
①	Housing		1	PA4T	Black
NO.	PART NAME	QTY	MATERIAL	DESCRIPTION	REMARK

KINY

东莞市摩凯电子有限公司

DIMENSIONS INIT: mm
UNLESS OTHERWISE SPECIFIABLE
DIMENSION TOLERANCE
X.X: ± 0.35
X.XX: ± 0.20
X.XXX: ± 0.10
ANGULAR: ± 2'

PRODUCT NAME : PHONE JACK	DRAWING: Alexander	DATE: 2020.08.25
PRODUCT NO. : PJK210-D1100-01	CHECK: Mark	DATE: 2020.08.25
DRAWING NO. : D-PJK210-D1100-01	APPROVED: Mark	DATE: 2020.08.25
SCALE: 1:1	DWG ID: C D	REV.: A
		PAGE: 1 OF 1

A	----	NEW RELEASE	Alexander	2020.08.25
REVISION NO.	ECR NO.	DESCRIPTION	MARK	DATE
1		2	3	