

\* 所有原料材质, 生产制程, 电镀必须符合HTR要求

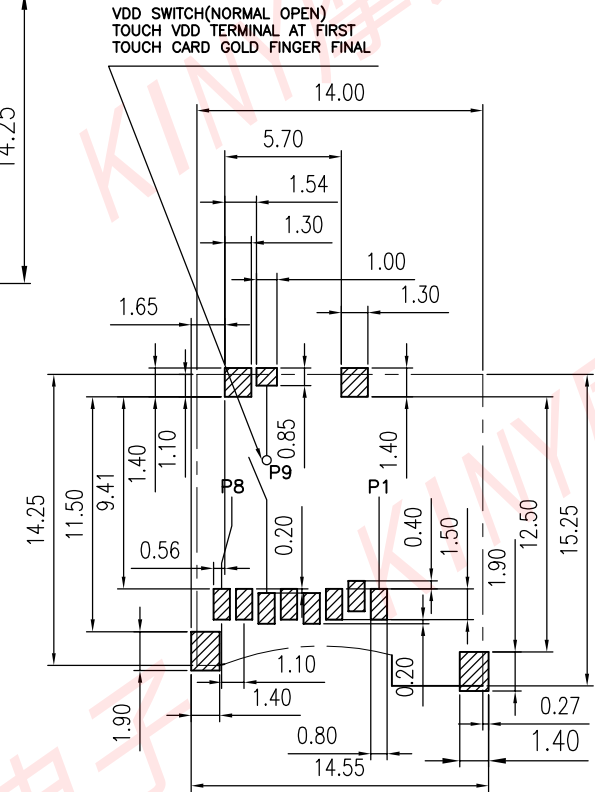
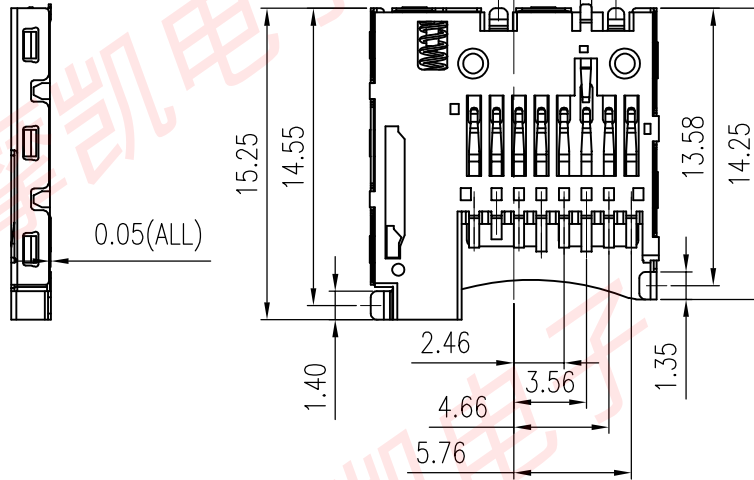
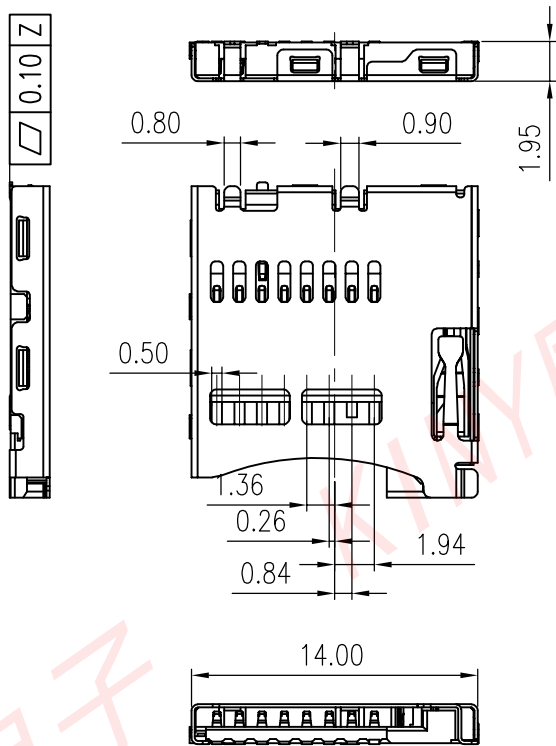

NOTES:

1. MATERIAL:

Housing: High Temperature Thermoplastic  
UL94V-0; Color Black.

Contacts: Phosphor Bronze.

Tin 80u" at Solder Tail,

Selected Gold Flash on Contact Area plating.

Shell: Stainless.

Gold Flash on Contact solder Area

Over Nickel Plating.

2. Electrical Characteristics:

Operating voltage :10v AC(rms)/DC.

Current rating :0.5 A.

Operating Temperature: -25°C~+85°C.

Insulation resistance: 1000M ohms min. at 500VDC

Dielectric withstanding voltage :500 VAC/1minute.

Contact resistance: 100m ohms max.

3. Mechanical characteristics

Insertion force: 40N Max.

Extraction force: 0.5N Min.

Mating durability: 10000 cycles at the speed rate of

400-600 cycles/h; Without distortion of plastic and serious wear and tear in terminal, No signal break.

开关插卡状态

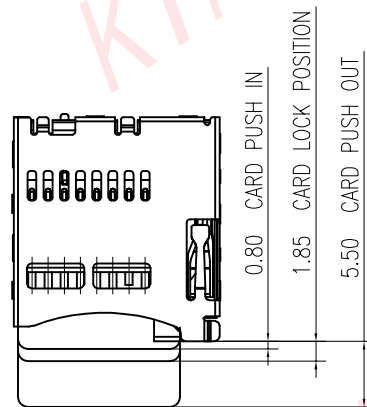
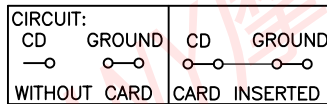

Pin No.	MICRO SD
PIN1	DAT2 1P
PIN2	CD/DAT3 2P
PIN3	CMD 3P
PIN4	VDD 4P
PIN5	CLK 5P
PIN6	VSS 6P
PIN7	DAT0 7P
PIN8	DAT1 8P
PIN9	CARD DETECT

**KINY**

东莞市摩凯电子有限公司

DIMENSIONS INIT: mm  
UNLESS OTHERWISE SPECIFIABLE

DIMENSION	TOLERANCE
X.X: ±	0.35
X.XX: ±	0.25
X.XXX: ±	0.10
ANGULAR: ±	2'

PRODUCT NAME : <b>MICRO SD P-P H1.95 内焊无柱</b>	DRAWING: <b>FAJI</b>	DATE: <b>2020.11.13</b>
PRODUCT NO. : <b>MC195-T1251-01</b>	CHECK: <b>Alex</b>	DATE: <b>2020.11.13</b>
DRAWING NO. : <b>D-MC195-T1251-01</b>	APPROVED: <b>Alex</b>	DATE: <b>2020.11.13</b>
SCALE: <b>1:1</b>	DWG ID: <b>C D</b>	REV.: <b>A</b>
PAGE: <b>1 of 1</b>		

A	----	NEW RELEASE	FAJI	2020.11.13
REVISION NO.	ECR NO.	DESCRIPTION	MARK	DATE
1				