

\* 所有原料材质, 生产制程, 电镀必须符合HTR要求

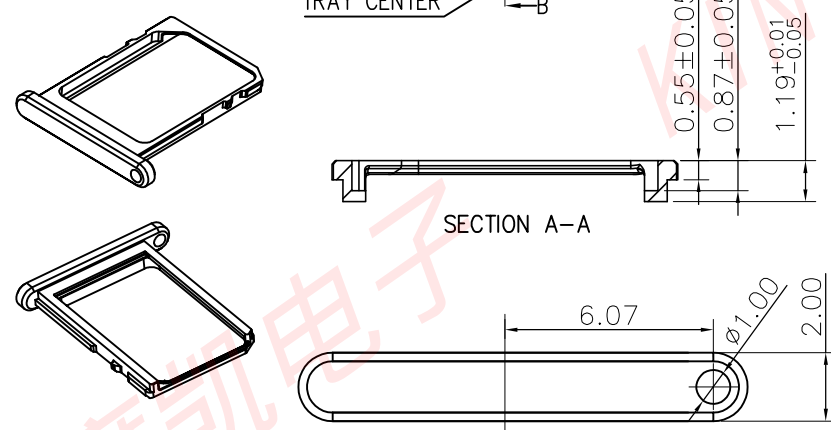
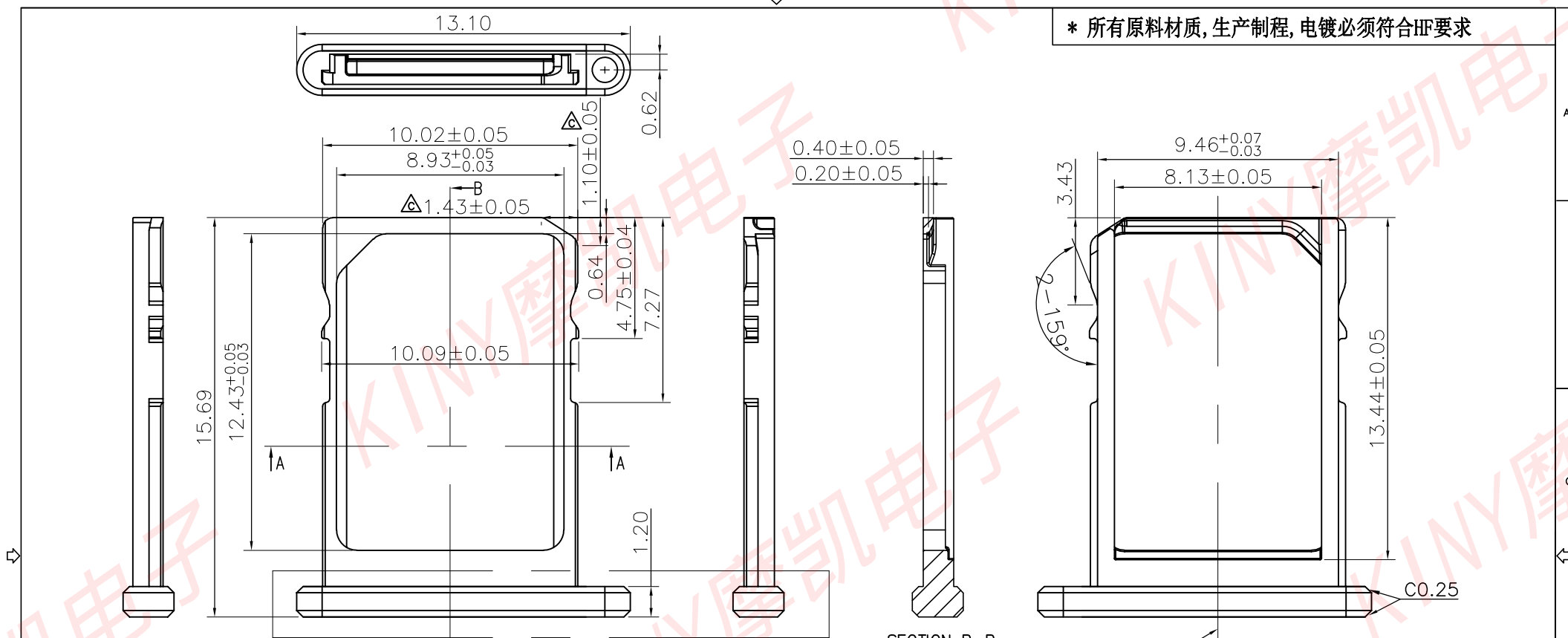

备注note:

1. 材料: 3号锌合金(Zamak3)  
1.Material: No. 3, zinc alloy(Zamak3)
2. 加工工艺: 压铸成型, SIM接触面局部绝缘处理。  
2.Process: Die casting molding, SIM contact local insulation treatment.
3. 外观处理: 产品全周无毛刺, 外观无划伤、压痕、油污、裂痕、扭曲变形等不良。  
3.Appearance: Product the week without burr, appearance no scratch and indentation, The oil bad distortion, cracks, deformation, etc.

D	ER2007086	变更名称 $\Delta$	pure	2020.07.13
C	ER2007086	增加尺寸管控 $\Delta$	jjaju.Li	2020.07.10
B	ECN20190826001	品名增加颜色及客户名称 $\Delta$	pure	2019.08.26
REVISION NO.	ECR NO.	DESCRIPTION	MARK	DATE

		东莞市摩凯电子有限公司			
DIMENSIONS INIT: mm		PRODUCT NO. : NSKT-Z0000-01		CHECK: Alex	DATE: 2020.07.13
UNLESS OTHERWISE SPECIFIABLE		DRAWING NO. : D-NSKT-Z0000-01		APPROVED: Alex	DATE: 2020.07.13
DIMENSION TOLERANCE		SCALE:	DWG ID: C D	REV.: D	PAGE: 1 OF 1
X.X: ± 0.35					
X.XX: ± 0.20					
X.XXX: ± 0.10					
ANGULAR: ± 2'					