

* 所有原料材质, 生产制程, 电镀必须符合H要求

检验图

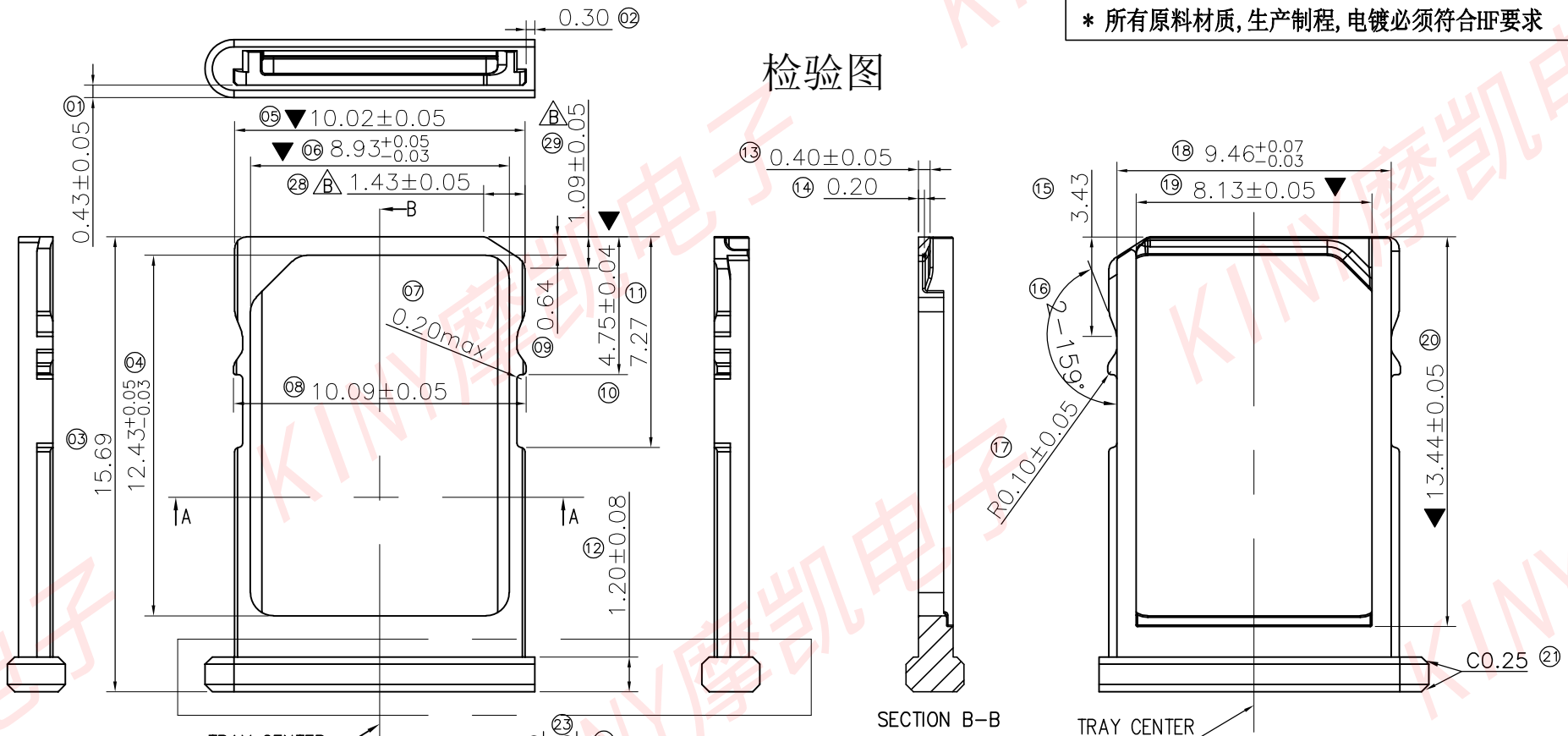

备注note:

1. 材料: 3号锌合金(Zamak3), 银色 ΔB
1.Material: No. 3, zinc alloy(Zamak3)
2. 加工工艺: 压铸成型, SIM接触面局部绝缘处理。
2.Process: Die casting molding, SIM contact local insulation treatment.
3. 外观处理: 产品全周无毛刺, 外观无划伤、压痕、油污、裂痕、扭曲变形等不良。
3.Appearance: Product the week without burr, appearance no scratch and indentation. The oil bad distortion, cracks, deformation, etc.

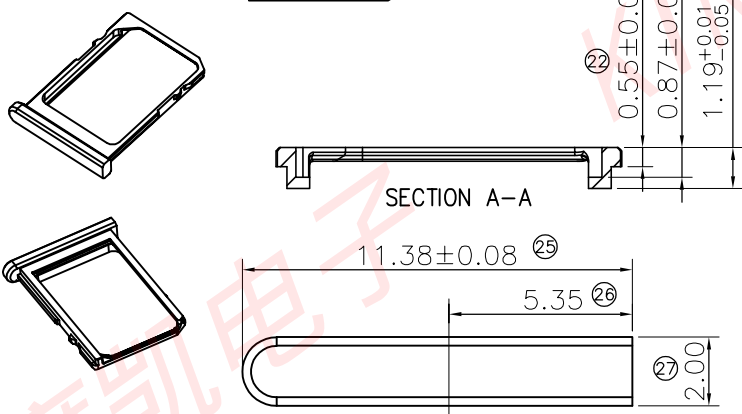

C	ER200414	依客户要求增加倒角尺寸管控 ΔC	Faji	2020.04.29
B	ECN20190826001	品名增加颜色及客户名称 ΔB	pure	2019.08.26
A	----		ping	2017.03.31
REVISION NO.	ECR NO.	DESCRIPTION	MARK	DATE

		东莞市摩凯电子有限公司			
DIMENSIONS INIT: mm		NANO SIM TRAY(无孔) 银色-其他	Faji	2020.04.29	
UNLESS OTHERWISE SPECIFIABLE		PRODUCT NO. :	CHECK:	DATE:	
DIMENSION TOLERANCE		NSKT-Z0000-05	Alex	2020.04.29	
X.X: ± 0.35		DRAWING NO. :	APPROVED:	DATE:	
X.XX: ± 0.20		D-NSKT-Z0000-05	Alex	2020.04.29	
X.XXX: ± 0.10		SCALE:		DWG ID:	
ANGULAR: ± 2'		REV.:		PAGE:	
		P D		C	
				1 OF 1	